

# DYNASAND<sup>®</sup>

CONTINUOUS, UPFLOW, GRANULAR MEDIA FILTER



# The DynaSand® Filter

Simplicity, low maintenance, outstanding performance

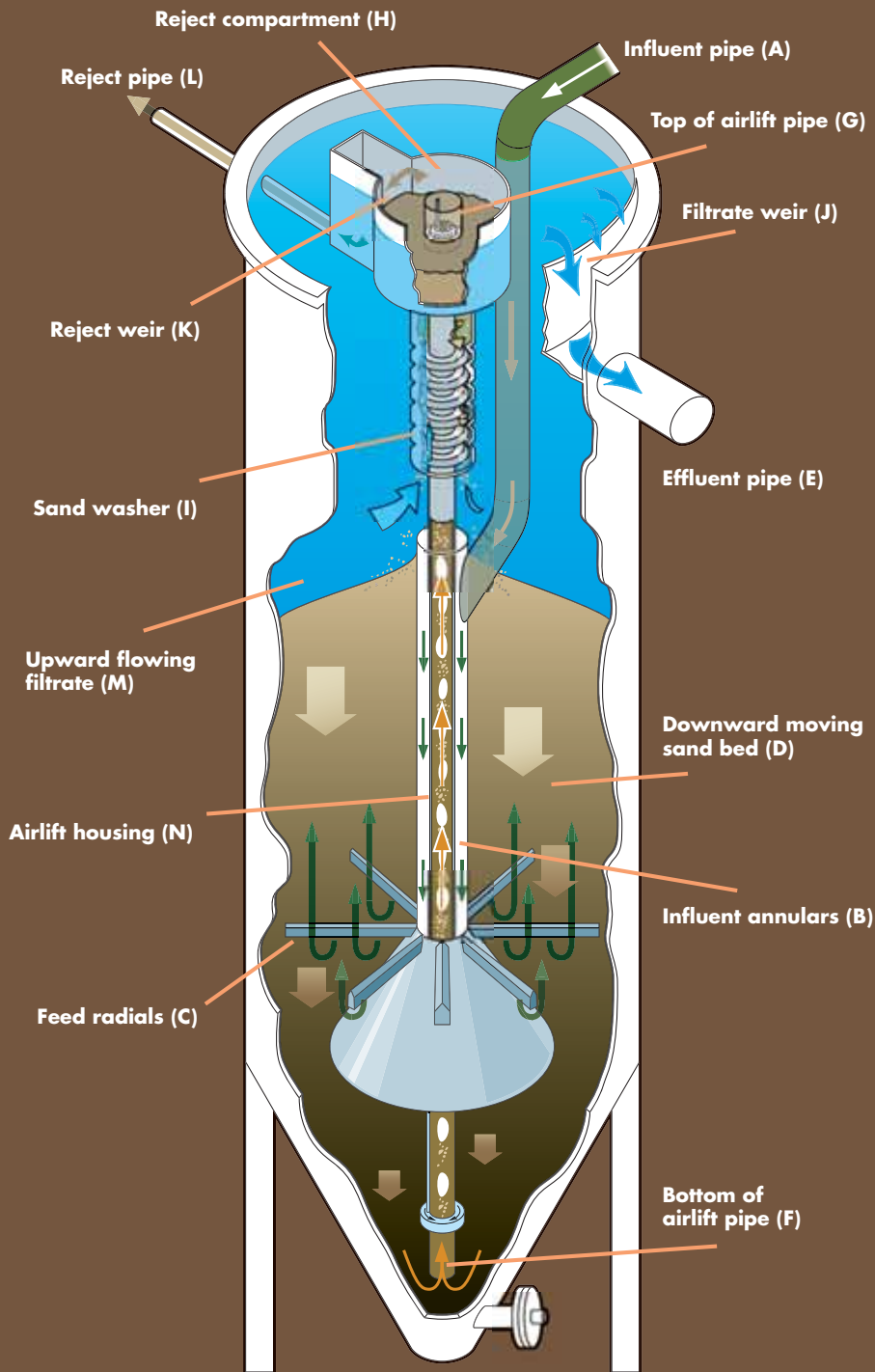

## DynaSand Principles of Operation

**Influent Filtration** Influent feed is introduced at the top of the filter (A) and flows downward through an annular section (B) between the influent feed pipe and airlift housing. The feed is introduced into the bottom of the sand bed through a series of feed radials (C) that are open at the bottom. As the influent flows upward (M) through the downward moving sand bed (D), organic and inorganic impurities are captured by the sand. The clean, polished filtrate continues to move upward and exits at the top of the filter over the filtrate weir (J) and out through the effluent pipe (E).

**Sand Cleaning** The sand bed containing captured impurities is drawn downward into the center of the filter where the airlift pipe (F) is located. A small volume of compressed air is introduced at the bottom of the airlift, drawing the sand into the airlift pipe. The sand is scoured within the airlift pipe at an intensity of 100-150 SCFM/ft<sup>2</sup>. The effectiveness of this scouring process is vastly greater than what can be expected in conventional sand filtration backwash. The scouring dislodges any solid particles attached to the sand grains.

The dirty slurry is pushed to the top of the airlift (G) and into the reject compartment (H). From the reject compartment, the sand falls into the sand washer (I) and the lighter reject solids are carried over the reject weir (K) and out the reject pipe (L). As the sand cascades down through the concentric stages of the washer, it encounters a small amount of polished filtrate moving upward, driven by the difference in water level between the filtrate pool and the reject weir. The heavier, coarser sand grains fall through this small countercurrent flow while the remaining contaminants are carried back up to the reject compartment. The clean, recycled sand is deposited on the top of the sand bed where it once again begins the influent cleaning process and its eventual migration to the bottom of the filter.

The DynaSand filter is an upflow, deep bed, granular media filter with continuous backwash. The filter media is cleaned by a simple internal washing system that does not require backwash pumps or storage tanks. The absence of backwash pumps means low energy consumption.

The DynaSand filter's deep media bed allows it

to handle high levels of suspended solids. This heavy-duty performance may eliminate the need for pre-sedimentation or flotation steps in the treatment process in some applications.

The DynaSand filter is available in various sizes and configurations. This flexibility allows for customization to fit specific site and application requirements.

## DynaSand® Filter Configurations

The DynaSand filter is available as either stand alone package units or in a modular concrete design. The package units are constructed of either 304 SST or FRP. Materials of construction for the internal components of both package and concrete units are SST and/or FRP. Filters are available in 40" standard bed or 80" deep-bed design depending on the nature of the application. Concrete modules are frequently used for high flow capacity systems by placing multiple modules into a common filter cell. The modules in a filter cell share a common filter bed where cones at the bottom of each module distribute sand to their respective airlifts and sand washers.



*DynaSand Filter above ground package units*

A concrete DynaSand installation can be designed for any size filter area. This enables the technology to be applied to any size water or wastewater treatment plant. Since all filter beds are being continuously cleaned, the pressure drop remains low and even throughout all the filters. Equal pressure drop ensures even distribution of feed to each filter without the need for splitter boxes or flow controls. Therefore, a typical multiple unit installation can use a common header pipe with feed connections and isolation valves for each filter.



*DynaSand Filter modules in concrete basin*

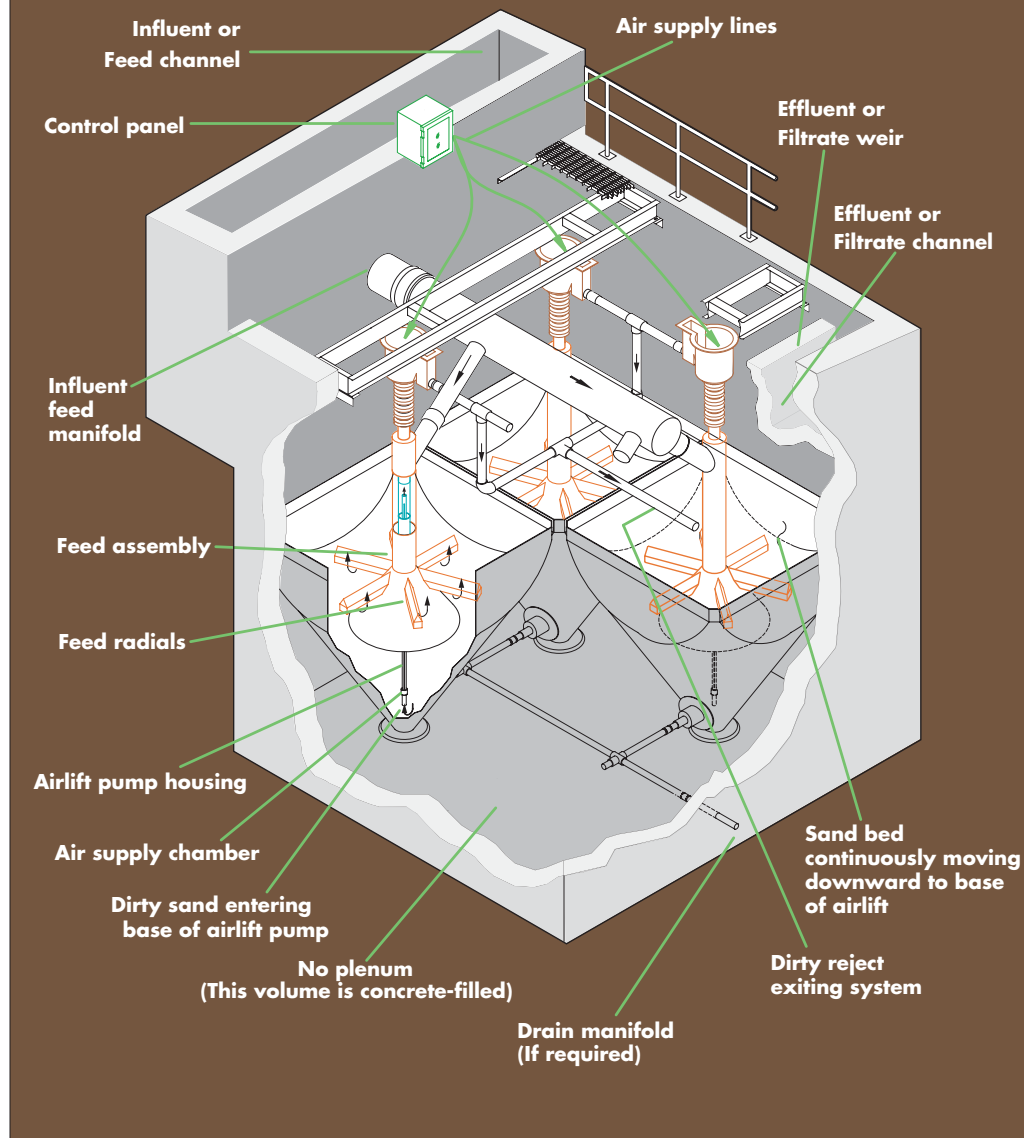

## Features

**Continuously Cleaned Sand Bed**

**No Underdrains or Screens**

**Sand Washed with Filtrate**

**No Level Control**

**Internal, Vertical Airlift**

**Low Power Requirements**

## Benefits

**No shutdown for backwash cycles**

**Elimination of ancillary backwash equipment**

**No flow control valves, splitter boxes, or backwash controls**

**No short-circuiting**

**Optimum sand-washing efficiency  
Superior filtrate quality**

**Reduced operator attention  
Minimizes overall pressure-drop**

**Reduces potential for pluggage  
Significantly reduces wear/maintenance  
Can be easily maintained without filter shutdown**

**Up to 70% less compressed air vs. other self-cleaning filters**

# DynaSand® Filter Continuous Contact Filtration Process

Water and wastewater treatment in conventional plants typically involves flocculation, clarification and filtration. Direct filtration eliminates clarification but still requires flocculation. The DynaSand filter utilizes a proprietary process known as Continuous Contact Filtration. The DynaSand filter's 80" media bed depth provides greater hydraulic residence times and more opportunity for floc formation and attachment. Thus, coagulation, flocculation and separation can be performed within the sand bed, eliminating the need for external flocculators and clarifiers. Equipment savings can be substantial, up to 85% compared to conventional treatment and 50% compared to direct filtration. The DynaSand Continuous Contact Filtration process is better suited to remove small floc, which can help reduce chemical requirements by 20-30% over conventional treatment.

**Applications** The DynaSand filter is currently providing exceptional treatment in over 8,000 installations worldwide in a wide variety of applications.

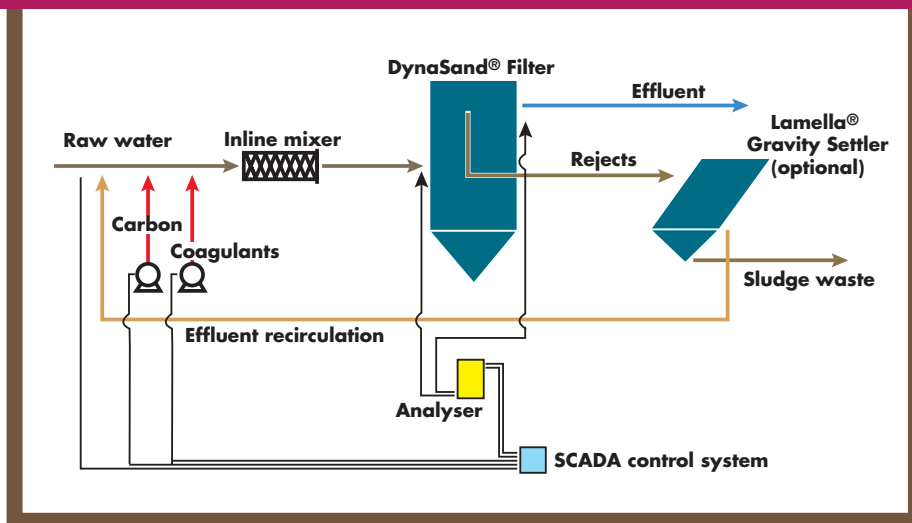

## DynaSand Applications – partial list

- Tertiary filtration • Algae removal • Potable water (turbidity and color) • Oil removal • Process water • Brine filtration
- Metal finishing • Cooling tower blowdown • Steel mill scale • Chemical processing • Phosphorous removal • Product recovery
- Denitrification • Cryptosporidium and Giardia removal • Surface water • Ground water • Arsenic removal • Effluent reuse

Typical Data	Loading rate (gpm/ft <sup>2</sup> )	Influent solids	Filtrate solids
<b>Tertiary Filtration</b>	<b>3-5</b>	<b>20-50 ppm SS</b>	<b>5-10 ppm SS</b>
<b>Potable Water – Turbidity</b>	<b>4-5</b>	<b>10-30 NTU</b>	<b>0.1-0.5 NTU</b>
<b>Potable Water – Color</b>	<b>4-5</b>	<b>10-120 ACU</b>	<b>1-5 ACU</b>
<b>Process Water</b>	<b>5</b>	<b>10-30 NTU</b>	<b>0.1-0.5 NTU</b>
<b>Metal Finishing</b>	<b>4-6</b>	<b>20-50 ppm SS</b>	<b>2-5 ppm SS</b>
<b>Steel Mill Scale</b>	<b>8-10</b>	<b>50-300 ppm SS</b>	<b>5-10 ppm SS</b>
<b>Phosphorus Removal</b>	<b>3-5</b>	<b>&lt;1 ppm Total P</b>	<b>&lt;0.1 ppm Total P</b>
<b>Algae Removal</b>	<b>2-4</b>	<b>100 ppm SS</b>	<b>10-20 ppm SS</b>
<b>Denitrification</b>	<b>3-4</b>	<b>10-15 ppm TN</b>	<b>&lt;3 ppm TN</b>
<b>Oil Removal</b>	<b>2-6</b>	<b>&lt;50 ppm O&amp;G</b>	<b>5-10 ppm O&amp;G</b>



[www.parkson.com](http://www.parkson.com)

AN AXEL JOHNSON INC. COMPANY

Parkson Florida  
Corporate  
2727 NW 62nd Street  
Fort Lauderdale FL  
33309-1721  
P.O. Box 408399  
Fort Lauderdale FL  
33340-8399  
P 954.974.6610  
F 954.974.6182

Parkson Illinois  
562 Bunker Court  
Vernon Hills IL  
60061-1831  
P 847.816.3700  
F 847.816.3707

Parkson Michigan  
2001 Waldorf St. NW  
Suite 300  
Grand Rapids MI  
49544-1437  
P 616.791.9100  
F 616.453.1832

Parkson Canada  
9045 Cote-de-Liesse  
Suite 201  
Dorval QC H9P 2M9  
Canada  
P 514.636.4618  
F 514.636.9718

Parkson do Brasil Ltda.  
Caçada dos Mirtilos, 15  
Barueri Sao Paulo  
CEP 06453-000  
Brazil  
P/F 55.11.4195.5084